

Shaft Couplings

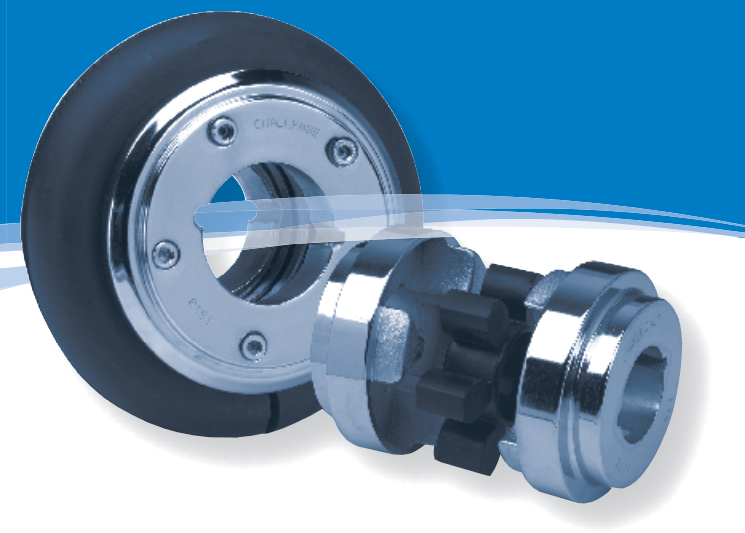

HRC Couplings

HRC Common Data

Coupling Size	Nominal Torque Nm	Overall Diameter A	Hub Diameter B	Assembled Length F	Element		Parallel Misalignment	Mass kg	Assembled Length (L)		
					Ring Dia E	Ring Width G			FF, FH, HH	FB,HB	BB
70	31	69	60	25.5	31	18.5	0.3	1.00	65.5	65.5	65.5
90	80	85	70	30.5	32	22.5	0.3	1.17	69.5	76.5	82.5
110	160	112	100	45.5	45	29.5	0.3	5.00	82.5	100.5	119.5
130	315	130	105	53.5	50	36.5	0.4	5.46	89.5	110.5	131.5
150	600	150	115	60.5	62	40.5	0.4	7.11	107.5	129.5	152.5
180	950	180	125	73.5	77	49.5	0.4	16.65	142.5	165.5	189.5
230	2000	225	155	85.5	99	59.5	0.5	26.05	164.5	202.5	239.5
280	3150	275	206	105.5	119	74.5	0.5	50.05	207.5	246.5	285.5

Angular misalignmet capacity up to 1 deg

Mass is for an FF, FH or HH coupling with mid range Taper Lock Bushes

F refers to combinations of flanges: FF, FH, HH, FB, HB, BB.

The elastomeric element in Challenge HRC couplings is manufactured from nitrile rubber with an operating temperature span between -40°C and +100°C.

HRC Type F & H

Coupling No	Bush size	Max. Bore		Shoulder Width D	Hub Width C
		mm	inch		
70	1008	25	1"	20.0	23.5
90	1108	28	1.1/8"	19.5	23.5
110	1610	42	1.5/8"	18.5	26.5
130	1610	42	1.5/8"	18.0	26.5
150	2012	50	2"	23.5	33.5
180	2517	65	2.1/2"	34.5	46.5
230	3020	75	3"	39.5	52.5
280	3525	100	4"	51.0	66.5

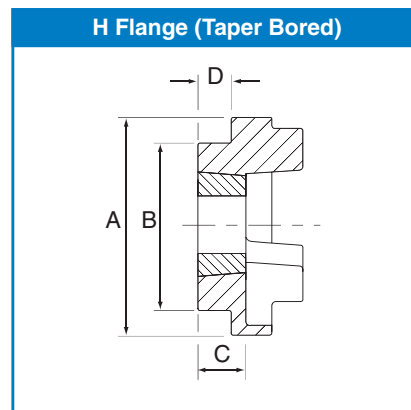
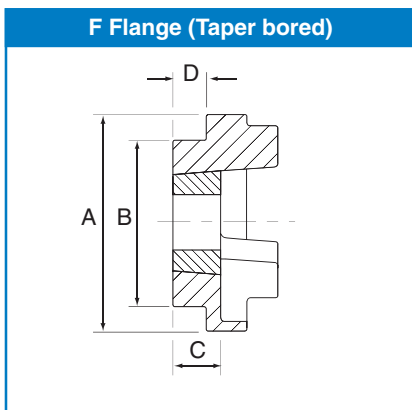
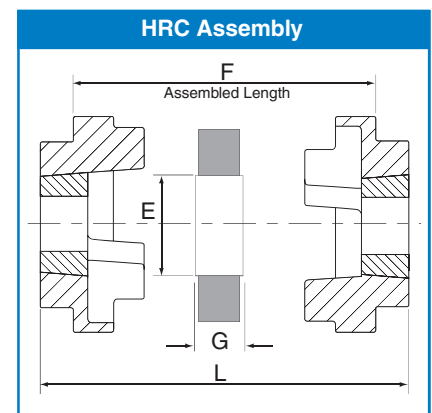

HRC Type B

Coupling No	Max. Bore	Pilot Bore	Keyway Screw Size	Shoulder Width D	Hub Width C
70	32	8	M 6	20	23.5
90	42	10	M 6	26	30.5
110	55	10	M10	37	45.5
130	60	15	M10	39	47.5
150	70	20	M10	46	56.5
180	80	25	M10	58	70.5
230	100	25	M12	77	90.5
280	115	30	M16	90	105.5

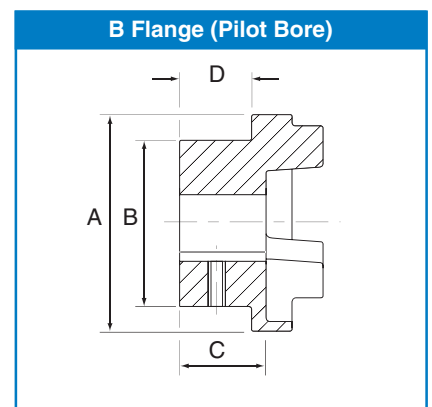

HRC Coupling Selection

HRC Coupling selection procedure

- 1] **Service Factor**
from table 1 on page 245, select the service factor that is appropriate for the application
- 2] **Design Power**
Multiply the absorbed power of the driven machine, in kW, by the service factor, from step 1) to obtain the design power. If the absorbed power is not known, use the prime mover power.
- 3] **HRC coupling size selection**
Refer to table 2 on page 245.
Read down the left hand vertical column to the required speed. Interpolate if the exact speed is not listed
Read horizontally across on the speed line until a power equal to or in excess of the design power, from step 2), is reached
Read vertically to the top of the column to obtain the correct size of HRC coupling.
- 4] **Bore dimensions**
From the dimension tables on page 243, check that the selected coupling will fit the shafts.

HRC Coupling selection example

Select a Challenge HRC coupling to couple an 11 kW, 970 rev/min motor to a machine tool which has to run for 16 hours/day. The motor shaft is 42 mm diameter and the machine tool shaft 38 mm diameter
Taper bush flanges are required for both shafts.

- 1] **Service factor**
From table 1 on page 245, the service factor for this application is 2.00
- 2] **Design power**
As the pump absorbed power is not known, the motor power is used as a basis for selecting the coupling.
The design power is $11 \times 2.00 = 22.0$ kW
- 3] **Tyre coupling size selection**
Refer to table 2 on page 245
By reading down and interpolating for the required speed of 970 rev/min, it is seen that an HRC 130 will transmit 32.0 kW which is in excess of the 22.0 kW required from step 2)
- 4] **Bore dimensions**
From the dimension table on page 243, the flanges on an HRC 130 take 1610 taper bushes which are available with bores to suit the shaft requirements of the application.

HRC Coupling Selection

Table 1, Service Factors

Special cases For applications where shock, vibration and torque fluctuations occur – consult Challenge	Type of prime mover					
	‘soft’ starts			‘heavy’ starts		
	Electric motors and other smooth running prime movers			Internal Combustion Engines		
	number of hours per day running					
Type of driven machine	under 10	10 - 16	over 16	under 10	10 - 16	over 16
Uniform load light duty agitators, belt conveyors for sand etc., fans upto 7.5 kW, centrifugal compressors and pumps,	1.0	1.12	1.25	1.25	1.40	1.60
Moderate load variable density agitators, belt conveyors (non-uniform loads), fans over 7.5 kW, other rotary compressors and pumps, machine tools, printing machinery, laundry machinery, rotary screens, rotary woodworking machinery	1.5	1.75	2.00	2.00	2.25	2.50
Heavy load reciprocating compressors and pumps, positive displacement blowers, heavy duty conveyors such as screw, bucket etc., hammer mills, pulverisers, presses, shears, punches, rubber machinery, crushers, metal mills	2.50	2.75	3.00	3.00	3.50	4.00

Table 2, Power Ratings (kW)

Rotational speed in rev/min	70	90	110	130	150	180	230	280
100	0.33	0.84	1.68	3.30	6.28	9.95	20.9	33.0
500	1.65	4.20	8.40	16.5	31.4	49.8	105	165
700	2.31	5.88	11.8	23.1	44.0	69.7	146	231
720	2.37	6.05	12.1	23.8	45.2	71.6	150	238
800	2.64	6.72	13.4	26.4	50.3	79.6	167	264
900	2.97	7.56	15.1	29.7	56.5	89.6	188	297
960	3.17	8.06	16.1	31.7	60.3	95.5	201	317
1000	3.33	8.40	16.8	33.0	62.8	99.5	209	330
1200	3.96	10.1	20.2	39.6	75.4	119	251	396
1400	4.62	11.8	23.5	46.2	87.9	139	293	462
1440	4.75	12.1	24.2	47.5	90.4	143	301	475
1500	4.95	12.6	25.2	49.5	94.2	149	314	495
1800	5.94	15.1	30.2	59.4	113	179	376	594
2000	6.60	16.8	33.6	66.0	126	199	418	660
2500	8.25	21.0	42.0	82.5	157	249	523	-
2880	9.50	24.2	48.4	95.0	181	287	-	-
3000	9.90	25.2	50.4	99.0	188	299	-	-
3500	11.6	29.4	58.8	116	220	348	-	-
4000	13.2	33.6	67.2	132	251	-	-	-
4500	14.9	37.8	75.6	149	283	-	-	-
5000	16.5	42.0	84.0	-	-	-	-	-

All power ratings are constant torque, interpolate for speeds not listed