

Shaft Couplings

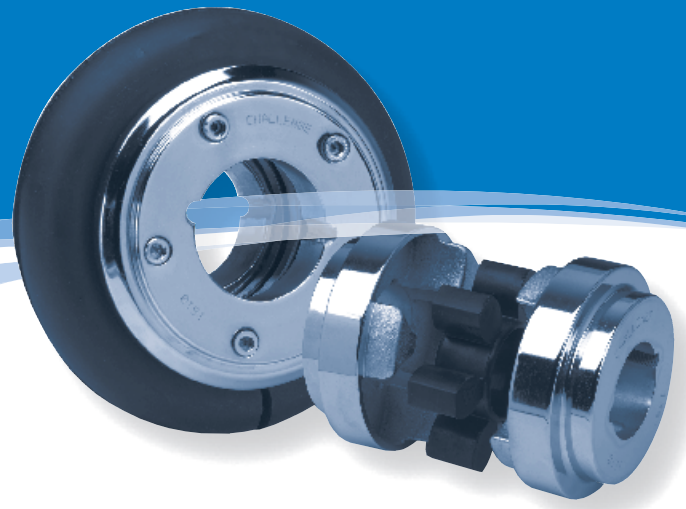

FFX Tyre Couplings

FFX Tyre Coupling Data

Coupling Size	Bush Size	Max Bore		A	B	C	E*	G	Types F & H		Type B		Keyway Setscrew	Mass# kg	Inertia# kgm ²
		Metric	Inch						F	D	F	D			
040B	—	32	—	104	—	82	11.0	29	—	—	33.0	22	M5	0.8	0.00074
040F	1008	25	1"	104	—	82	11.0	29	33.0	22	—	—	—	0.8	0.00074
040H	1008	25	1"	104	—	82	11.0	29	33.0	22	—	—	—	0.8	0.00074
050B	—	38	—	133	79	100	12.5	38	—	—	45.0	32	M5	1.2	0.00115
050F	1210	32	1.1/4"	133	79	100	12.5	38	38.0	25	—	—	—	1.2	0.00115
050H	1210	32	1.1/4"	133	79	100	12.5	38	38.0	25	—	—	—	1.2	0.00115
060B	—	45	—	165	70	125	16.5	38	—	—	55.0	38	M6	2.0	0.0052
060F	1610	42	1.5/8"	165	103	125	16.5	38	42.0	25	—	—	—	2.0	0.0052
060H	1610	42	1.5/8"	165	103	125	16.5	38	42.0	25	—	—	—	2.0	0.0052
070B	—	50	—	187	80	144	11.5	—	—	—	47.0	35	M10	3.1	0.009
070F	2012	50	2"	187	80	144	11.5	42	44.0	32	—	—	—	3.1	0.009
070H	1610	42	1.5/8"	187	80	144	11.5	38	42.0	25	—	—	—	3.0	0.009
080B	—	60	—	211	98	167	12.5	—	—	—	55.0	42	M10	4.9	0.018
080F	2517	65	2.1/2"	211	97	167	12.5	48	58.0	45	—	—	—	4.9	0.018
080H	2012	50	2"	211	98	167	12.5	42	45.0	32	—	—	—	4.6	0.017
090B	—	70	—	235	112	188	13.5	—	—	—	63.5	49	M12	7.1	0.032
090F	2517	65	2.1/2"	235	108	188	13.5	48	59.5	45	—	—	—	7.0	0.031
090H	2517	65	2.1/2"	235	108	188	13.5	48	59.5	45	—	—	—	7.0	0.031
100B	—	80	—	254	125	216	13.5	—	—	—	70.5	56	M12	9.9	0.055
100F	3020	75	3"	254	120	216	13.5	55	65.5	51	—	—	—	9.9	0.055
100H	2517	65	2.1/2"	254	113	216	13.5	48	59.5	45	—	—	—	9.4	0.054
110B	—	90	—	279	128	233	12.5	—	—	—	75.5	63	M12	12.5	0.081
110F	3020	75	3"	279	134	233	12.5	55	63.5	51	—	—	—	11.7	0.078
110H	3020	75	3"	279	134	233	12.5	55	63.5	51	—	—	—	11.7	0.078
120B	—	100	—	314	143	264	14.5	—	—	—	84.5	70	M16	16.9	0.137
120F	3525	100	4"	314	140	264	14.5	67	79.5	65	—	—	—	16.5	0.137
120H	3020	75	3"	314	140	264	14.5	55	65.5	51	—	—	—	15.9	0.13
140B	—	130	—	359	178	311	16.0	—	—	—	110.5	94	M20	22.2	0.254
140F	3525	100	4"	359	178	311	16.0	67	81.5	65	—	—	—	22.3	0.255
140H	3525	100	4"	359	178	311	16.0	67	81.5	65	—	—	—	22.3	0.255
160B	—	140	—	402	187	345	15.0	—	—	—	117.0	102	M20	35.8	0.469
160F	4030	115	4.1/2"	402	197	345	15.0	80	92.0	77	—	—	—	32.5	0.38
160H	4030	115	4.1/2"	402	197	345	15.0	80	92.0	77	—	—	—	32.5	0.38
180B	—	150	—	470	200	398	23.0	—	—	—	137.0	114	M20	49.1	0.871
180F	4535	125	5"	470	205	398	23.0	89	112.0	89	—	—	—	42.2	0.847
180H	4535	125	5"	470	205	398	23.0	89	112.0	89	—	—	—	42.2	0.847
200B	—	150	—	508	200	429	24.0	—	—	—	138.0	114	M20	58.2	1.301
200F	4535	125	5"	508	205	429	24.0	89	113.0	89	—	—	—	53.6	1.281
200H	4535	125	5"	508	205	429	24.0	89	113.0	89	—	—	—	53.6	1.281
220B	—	160	—	562	218	474	27.5	—	—	—	154.5	127	M20	79.6	2.142
220F	5040	125	5"	562	223	474	27.5	92	129.5	102	—	—	—	72.0	2.104
220H	5040	125	5"	562	223	474	27.5	92	129.5	102	—	—	—	72.0	2.104
250B	—	190	—	628	254	532	29.5	—	—	—	161.5	132	M20	104.0	3.505

Notes

G = Wrench clearance needed to allow for the tightening or loosening of the bush on the shaft as well as the tyre clamping screws.

* = Half the distance required between flanges faces

= Mass and inertia figures are for a single flange including mid range bore, clamping ring, screws and half tyre.

Fire resistant and anti static tyres are available - consult Challenge

Challenge standard tyres are manufactured from natural rubber with an operating temperature span between -50°C and +50°C.

Challenge FRAS tyres are manufactured from chloroprene and have an operating temperature span between -15°C and +70°C

All Challenge FFX Flanges are produced from steel

FFX Tyre Couplings

FFX Tyre Coupling Data

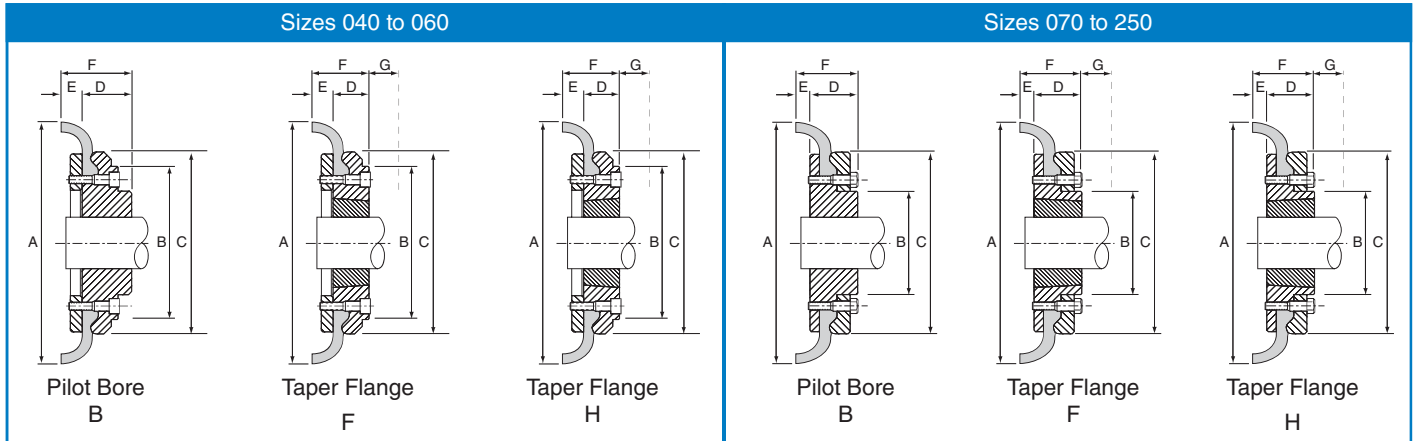

FFX Coupling Installation and Operational Data

Coupling Size	Flange Face Spacing mm	Gap Between Tyre Ends mm	Nominal Torque Nm	Max Speed rev/min	Max Parallel Misalignment	Max End Float*	Clamping Screw	
							Size	Torque Nm
40	22	2	24	4500	1.1	1.3	M6	15
50	25	2	66	4500	1.3	1.7	M6	15
60	33	2	127	4000	1.6	2.0	M6	15
70	23	3	250	3600	1.9	2.3	M8	24
80	25	3	375	3100	2.1	2.6	M8	24
90	27	3	500	3000	2.4	3.0	M10	40
100	27	3	675	2600	2.6	3.3	M10	40
110	25	3	875	2300	2.9	3.7	M10	40
120	29	3	1330	2050	3.2	4.0	M12	50
140	32	5	2325	1800	3.7	4.6	M12	55
160	30	5	3770	1600	4.2	5.3	M16	80
180	46	6	6270	1500	4.8	6.0	M16	105
200	48	6	9325	1300	5.3	6.6	M16	120
220	55	6	11600	1100	5.8	7.3	M20	165
250	59	6	14675	1000	6.6	8.2	M20	165

NB. All flexible tyres have an angular misalignment capacity up to 4°.

* End Float, alternatively called axial misalignment

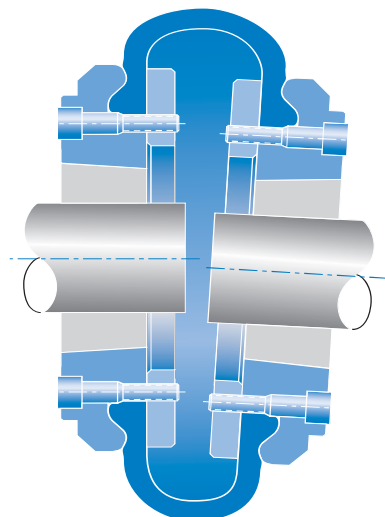

Accommodate simultaneous maximum misalignment in all planes.

FFX Tyre Coupling Selection

Tyre Coupling selection procedure

- 1] **Service Factor.**
From table 1 on page 241, select the service factor that is appropriate for the application
- 2] **Design Power.**
Multiply the absorbed power of the driven machine, in kW, by the service factor, from step 1) to obtain the design power.
If the absorbed power is not known, use the prime mover power.
- 3] **Tyre coupling size selection.**
Refer to table 2 on page 241.
Read down the left hand vertical column to the required speed
Read horizontally across on the speed line until a power equal to or in excess of the design power, from step 2), is reached.
Read vertically to the top of the column to obtain the correct size of tyre coupling.
- 4] **Bore dimensions.**
From the dimensions table on page 238, check that the selected coupling will fit the shafts.

Tyre Coupling selection example

Select a Challenge tyre coupling to drive a reciprocating pump from a 980 rev/min, 30 kW electric motor. The pump absorbs 24 kW and runs for 18 hours/day.

The motor shaft is 60 mm diameter and the pump shaft 55 mm diameter. Taper bush flanges are required for both shafts.

- 1] **Service factor.**
From table 2 on page 241, the service factor for this application is 1.9
- 2] **Design power.**
Using the absorbed power of the pump, the design power is $24 \times 1.9 = 45.6 \text{ kW}$
- 3] **Tyre coupling size selection.**
Refer to table 2 on page 241
By reading down and interpolating for the required speed of 980 rev/min, it is seen that an FFX 090 will transmit 50.6 kW which is in excess of the 45.6 kW required from step 2)
- 4] **Bore dimensions.**
From the dimensions table on page 238, it is seen that both 'F' and 'H' flanges on an FFX 090 take a 2517 taper bush which are available with bores to suit the shaft requirements of the application.

FFX Tyre Coupling Selection

Table 1, Service Factors

Special cases For applications where shock, vibration and torque fluctuations occur – consult Challenge	Type of prime mover					
	'soft' starts			'heavy' starts		
	Electric motors and other smooth running prime movers			Internal Combustion Engines		
	number of hours per day running					
Type of driven machine	under 10	10 - 16	over 16	under 10	10 - 16	over 16
Uniform load light duty agitators, belt conveyors for sand etc., fans upto 7.5 kW, centrifugal compressors and pumps,	0.8	0.9	1.0	1.3	1.4	1.5
Moderate load variable density agitators, belt conveyors (non-uniform loads), fans over 7.5 kW, other rotary compressors and pumps, generators, machine tools, printing machinery, laundry machinery, rotary screens, rotary woodworking machinery	1.3	1.4	1.5	1.8	1.9	2.0
Heavy load reciprocating compressors and pumps, positive displacement blowers, heavy duty conveyors such as screw, bucket etc., hammer mills, pulverisers, presses, shears, punches, rubber machinery	1.8	1.9	2.0	2.3	2.4	2.5
Severe load crushers – gyratory, jaw, roll etc., rolling mills, calenders, quarry machinery, vibrating screens	2.3	2.4	2.5	2.8	2.9	3.0

Table 2, Power Ratings (kW)

Rotational speed in rev/min	F40	F50	F60	F70	F80	F90	F100	F110	F120	F140	F160	F180	F200	F220	F250
100	0.28	0.87	1.58	2.59	4.06	5.16	6.83	9.09	14.2	26.7	41.8	65.4	96.8	120	154
500	1.41	4.36	7.88	12.9	20.2	25.7	34.1	45.4	71.4	134	209	327	484	601	767
700	1.97	6.10	11.0	18.1	28.4	36.0	47.7	63.6	99.8	187	292	458	678	842	1074
720	2.02	6.26	11.3	18.6	29.2	37.1	49.1	65.4	103	192	301	471	697	866	1104
800	2.25	6.97	12.5	20.7	32.4	41.2	54.5	72.3	114	214	334	523	775	962	1227
900	2.53	7.84	14.1	23.3	36.5	46.3	61.4	81.8	128	241	376	589	872	1082	1380
960	2.69	8.36	15.1	24.8	38.9	49.4	65.5	87.3	137	257	401	628	929	1154	1472
1000	2.81	8.71	15.7	25.9	40.6	51.5	68.2	90.9	143	267	419	655	968	1203	1534
1200	3.37	10.4	18.9	31.0	48.6	61.8	81.8	109	171	321	502	785	1162	-	-
1400	3.93	12.2	22.0	36.2	56.8	72.1	95.5	127	200	375	585	916	-	-	-
1440	4.04	12.5	22.6	37.2	58.4	74.2	98.3	131	206	385	602	942	-	-	-
1500	4.21	13.0	23.6	38.8	60.9	77.3	102	136	214	401	627	982	-	-	-
1800	5.05	15.6	28.3	46.5	73.0	92.7	123	164	257	481	-	-	-	-	-
2000	5.62	17.4	31.5	51.8	81.1	103	136	182	286	-	-	-	-	-	-
2500	7.02	21.7	39.3	64.7	102	129	145	-	-	-	-	-	-	-	-
2880	8.08	25.0	45.3	74.5	117	149	-	-	-	-	-	-	-	-	-
3000	8.42	26.1	47.2	77.6	122	155	-	-	-	-	-	-	-	-	-
3500	9.82	30.4	55.1	90.6	-	-	-	-	-	-	-	-	-	-	-
4000	11.2	34.8	63.0	-	-	-	-	-	-	-	-	-	-	-	-
4500	12.6	39.1	-	-	-	-	-	-	-	-	-	-	-	-	-

All power ratings are constant torque
interpolate for speeds not listed

Every effort has been taken to ensure that the data listed in this catalogue is correct. Challenge accepts no liability for any inaccuracies or damage caused.

FFX Tyre Coupling Installation

Installation instructions

- 1] Clean all parts
- 2] Assemble the flanges onto the shafts after connecting the clamping rings loosely to them
- 3] Move the flanges along the shafts until dimension 'M' is obtained (see table 3). Ensure there is sufficient gap between the shaft ends to allow for any axial movement
- 4] Check the alignment in both parallel and angular planes to ensure the shafts are aligned as accurately as possible – the more accurate the alignment, the less the tyre wear. See table 3 for misalignment values
- 5] Fit the tyre into the gap between the flange and clamping ring, ensuring the tyre bead is correctly located. When correctly seated, the tyre gap should match the value in table 4
- 6] Tighten the clamping ring screws alternately, and gradually, until the correct torque is achieved (see table 3)

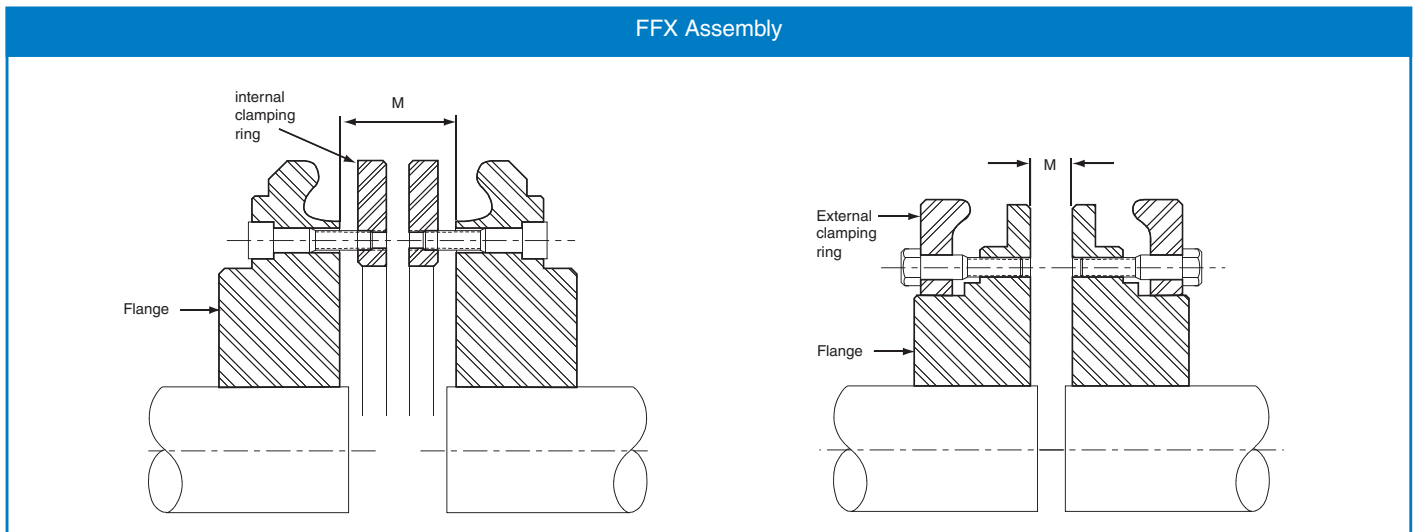

Table 3

FFX Coupling size	040	050	060	070	080	090	100	110	120	140	160	180	200	220	250
Parallel misalignment	1.0	1.3	1.6	1.9	2.1	2.4	2.6	2.9	3.2	3.7	4.2	4.8	5.3	5.8	6.6
Axial (end float) misalignment	1.3	1.7	2.0	2.3	2.6	3.0	3.3	3.7	4.0	4.6	5.3	6.0	6.6	7.3	8.2
Angular misalignment	4°	4°	4°	4°	4°	4°	4°	4°	4°	4°	4°	4°	4°	4°	4°
M dimension	22	25	33	23	25	27	27	25	29	32	30	46	48	55	59
Clamping ring screw torque - Nm	15	15	15	24	24	40	40	40	50	55	80	105	120	165	165

Table 4

FFX Coupling Size	040 to 060	070 to 120	140 to 160	180 to 250
Tyre Gap	2	3	5	6