

Taper Bushes

Range and Material Specifications:

Challenge Taper Bushes are manufactured to the highest quality standards using GG22 - 25 cast iron depending on size. Thin wall bushes are produced from C45 steel. All surfaces are carefully machined to provide maximum contact area and transmission of torque.

In excess of 500 sizes of Challenge Taper Bushes are manufactured and stocked making this one of the most comprehensive ranges available today.

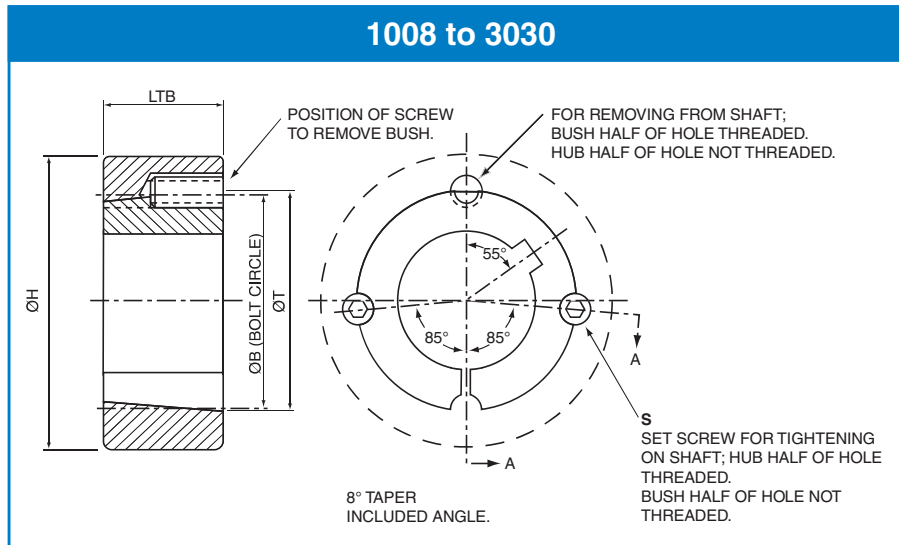

Taper Bush 1008 to 3030

Bush Size	OT	LTB	Minimum hub Dia H			OB	Set Screws S	
			200 N/mm ² GG Iron	250 N/mm ² GG Iron	420 N/mm ² Steel		Quantity	Size (BSW)
1008	35.20	22.3	59	54	51	33.73	2	1/4" x 1/2"
1108	38.38	22.3	61	57	54	36.92	2	1/4" x 1/2"
1210	47.62	25.4	99	86	78	44.44	2	3/8" x 5/8"
1215	47.62	38.1	79	73	68	44.44	2	3/8" x 5/8"
1310	50.80	25.4	100	88	80	47.63	2	3/8" x 5/8"
1610	57.15	25.4	102	92	85	53.97	2	3/8" x 5/8"
1615	57.15	38.1	86	81	77	53.97	2	3/8" x 5/8"
2012	69.85	31.8	115	106	99	66.68	2	7/16" x 7/8"
2517	85.73	44.5	125	119	113	82.55	2	1/2" x 1"
2525	85.73	63.5	115	111	108	82.56	2	1/2" x 1"
3020	107.96	50.8	154	146	140	101.60	2	5/8" x 1.1/4"
3030	107.96	76.2	141	136	132	101.60	2	5/8" x 1.1/4"

Severe operating conditions may require the use of a larger diameter hub.

Taper Bushes

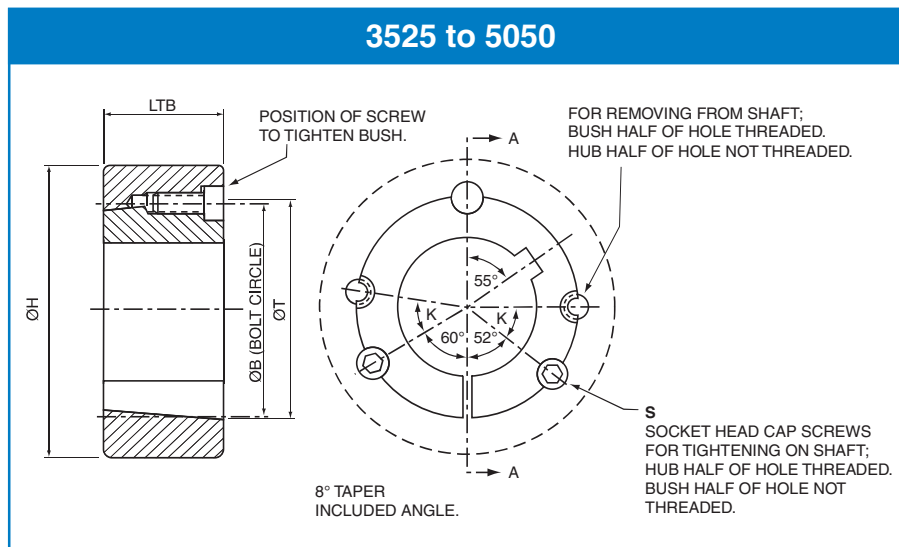

Taper Bush 3525 to 5050

Bush Size.	OT	LTB	Minimum hub Dia H			OB	Cap Screws S		K
			200 N/mm ² GG Iron	250 N/mm ² GG Iron	420 N/mm ² Steel		Quantity	Size (BSW)	
3525	127.00	63.5	206	191	178	122.68	3	1/2" x 1.1/2"	40°
3535	127.00	89.0	185	176	168	122.68	3	1/2" x 1.1/2"	40°
4030	146.05	76.2	220	207	197	140.72	3	5/8" x 1.3/4"	40°
4040	146.05	101.5	203	195	188	140.72	3	5/8" x 1.1/4"	40°
4535	161.93	89.0	221	212	205	455.70	3	3/4" x 2"	40°
4545	161.93	114.3	211	205	200	155.70	3	3/4" x 2"	40°
5040	177.80	101.6	236	229	223	170.69	3	7/8" x 2.1/4"	37°
5050	177.80	127.0	230	223	219	170.69	3	7/8" x 2.1/4"	37°

Severe operating conditions may require the use of a larger diameter hub.

Taper Bushes

To Install

1. Clean shaft, bore and outside of bush, and bore of hub. Remove any oil, laquer or dirt. Place bush in hub and match half holes to make complete holes (each complete hole will be threaded on one side only).
2. Lightly oil thread and point of set screws, or thread and under head of cap screws. Place screws loosely in holes that are threaded on hub side.
3. Make sure bush is free in hub. Slip assembly onto shaft and locate in the desired position.
4. Tighten screws alternately and evenly until all are pulled up tightly (See table for torque settings).
5. Hammer against large end of bush using hammer and block or sleeve to avoid damage. Screws can now be turned a little more to the specified torque setting. Repeat this alternate hammering and screw re-tightening until the specified torque is reached. Fill all holes with grease to exclude dirt.

To Remove

1. Remove all screws (●). Lightly oil thread and point of set screws, or thread and under head of cap screws.
2. Insert screws into removal holes that are threaded on the bush side (☺). In sizes where washers are found under screw heads, be sure to use these washers.
3. Tighten screws alternately until bush is loosened in hub and then remove the complete assembly. If bush does not loosen immediately, tap on hub.

1008 to 3030

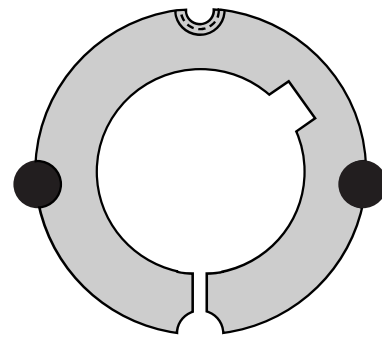

3525 to 5050

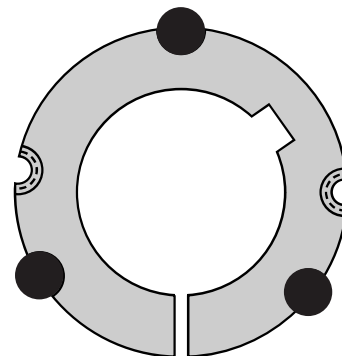

Recommended Wrench Torque

Bush Size	Screws	Tightening Torque (Nm)	Bush Size	Screws	Tightening Torque (Nm)	Bush Size	Screws	Tightening Torque (Nm)
1008	1/4" Set Screws	6	2012	7/16" Set Screws	30	4030	5/8" Cap Screws	170
1108	1/4" Set Screws	6	2517	1/2" Set Screws	50	4040	5/8" Cap Screws	170
1210	3/8" Set Screws	20	2525	1/2" Set Screws	50	4535	3/4" Cap Screws	190
1215	3/8" Set Screws	20	3020	5/8" Set Screws	90	4545	3/4" Cap Screws	190
1310	3/8" Set Screws	20	3030	5/8" Set Screws	90	5040	7/8" Cap Screws	270
1610	3/8" Set Screws	20	3525	1/2" Cap Screws	105	5050	7/8" Cap Screws	270
1615	3/8" Set Screws	20	3535	1/2" Cap Screws	105			

All dimensions in millimetres unless otherwise stated. Every effort has been taken to ensure that the data listed in this catalogue is correct. Challenge accepts no liability for any inaccuracies or damage caused.

Taper Bushes - Imperial

1008

Bore	Mass kg	Keyseat	
		Bush	Shaft
3/8	0.14	0.125 x 0.060	0.125 x 0.072
1/2	0.13	0.125 x 0.060	0.125 x 0.072
5/8	0.12	0.188 x 0.088	0.188 x 0.107
3/4	0.11	0.188 x 0.088	0.188 x 0.107
13/16	0.10	0.250 x 0.115	0.250 x 0.142
7/8	0.09	0.250 x 0.115	0.250 x 0.142
15/16	0.08	0.250 x 0.115	0.250 x 0.142
1*	0.07	0.250 x 0.053*	0.250 x 0.142

1108

Bore	Mass kg	Keyseat	
		Bush	Shaft
3/8	0.17	0.125 x 0.060	0.125 x 0.072
7/16	0.16	0.125 x 0.060	0.125 x 0.072
1/2	0.16	0.125 x 0.060	0.125 x 0.072
9/16	0.15	0.188 x 0.088	0.188 x 0.107
5/8	0.15	0.188 x 0.088	0.188 x 0.107
11/16	0.14	0.188 x 0.088	0.188 x 0.107
3/4	0.14	0.188 x 0.088	0.188 x 0.107
13/16	0.13	0.250 x 0.115	0.250 x 0.142
7/8	0.12	0.250 x 0.115	0.250 x 0.142
1	0.10	0.250 x 0.115	0.250 x 0.142
1.1/16	0.09	0.312 x 0.112	0.312 x 0.177
1.1/8*	0.08	0.312 x 0.080*	0.312 x 0.177

1210

Bore	Mass kg	Keyseat	
		Bush	Shaft
1/2	0.30	0.125 x 0.060	0.125 x 0.072
5/8	0.28	0.188 x 0.088	0.188 x 0.107
11/16	0.27	0.188 x 0.088	0.188 x 0.107
3/4	0.26	0.188 x 0.088	0.188 x 0.107
13/16	0.25	0.250 x 0.115	0.250 x 0.142
7/8	0.24	0.250 x 0.115	0.250 x 0.142
15/16	0.23	0.250 x 0.115	0.250 x 0.142
1	0.21	0.250 x 0.115	0.250 x 0.142
1.1/8	0.19	0.312 x 0.112	0.312 x 0.177
1.3/16	0.18	0.312 x 0.112	0.312 x 0.177
1.1/4	0.16	0.312 x 0.112	0.312 x 0.177

1215

Bore	Mass kg	Keyseat	
		Bush	Shaft
5/8	0.42	0.188 x 0.088	0.188 x 0.107
3/4	0.40	0.188 x 0.088	0.188 x 0.107
7/8	0.36	0.250 x 0.115	0.250 x 0.142
1	0.32	0.250 x 0.115	0.250 x 0.142
1.1/8	0.28	0.312 x 0.112	0.312 x 0.177
1.1/4	0.24	0.312 x 0.112	0.312 x 0.177

1310

Bore	Mass kg	Keyseat	
		Bush	Shaft
1/2	0.35	0.125 x 0.060	0.125 x 0.072
5/8	0.34	0.188 x 0.088	0.188 x 0.107
3/4	0.32	0.188 x 0.088	0.188 x 0.107
7/8	0.30	0.250 x 0.115	0.250 x 0.142
1	0.28	0.250 x 0.115	0.250 x 0.142
1.1/8	0.25	0.312 x 0.112	0.312 x 0.177
1.1/4	0.22	0.312 x 0.112	0.312 x 0.177
1.3/8	0.19	0.375 x 0.11	0.375 x 0.213

1610

Bore	Mass kg	Keyseat	
		Bush	Shaft
1/2	0.46	0.125 x 0.060	0.125 x 0.072
5/8	0.44	0.188 x 0.088	0.188 x 0.107
3/4	0.42	0.188 x 0.088	0.188 x 0.107
7/8	0.40	0.250 x 0.115	0.250 x 0.142
15/16	0.39	0.250 x 0.115	0.250 x 0.142
1	0.38	0.250 x 0.115	0.250 x 0.142
1.1/16	0.37	0.312 x 0.112	0.312 x 0.177
1.1/8	0.35	0.312 x 0.112	0.312 x 0.177
1.3/16	0.34	0.312 x 0.112	0.312 x 0.177
1.1/4	0.32	0.312 x 0.112	0.312 x 0.177
1.5/16	0.31	0.375 x 0.11	0.375 x 0.213
1.3/8	0.29	0.375 x 0.11	0.375 x 0.213
1.7/16	0.27	0.375 x 0.11	0.375 x 0.213
1.1/2	0.25	0.375 x 0.11	0.375 x 0.213
1.5/8	0.21	0.438 x 0.134	0.438 x 0.248

1615

Bore	Mass kg	Keyseat	
		Bush	Shaft
1/2	0.66	0.125 x 0.060	0.125 x 0.072
5/8	0.64	0.188 x 0.088	0.188 x 0.107
3/4	0.61	0.188 x 0.088	0.188 x 0.107
7/8	0.58	0.250 x 0.115	0.250 x 0.142
1	0.55	0.250 x 0.115	0.250 x 0.142
1.1/8	0.51	0.312 x 0.112	0.312 x 0.177
1.1/4	0.46	0.312 x 0.112	0.312 x 0.177
1.3/8	0.41	0.375 x 0.11	0.375 x 0.213
1.7/16	0.39	0.375 x 0.11	0.375 x 0.213
1.1/2	0.36	0.375 x 0.11	0.375 x 0.213
1.5/8*	0.30	0.438 x 0.103*	0.438 x 0.248

Bold italic type indicates bushes made of steel.

Keyways are parallel and in accordance with BS46: Part 1:1958, with the exception of those marked* which are shallower.

Depth of key measured at centre

All dimensions are in inches

Taper Bushes - Imperial

2012

Bore	Mass kg	Keyseat	
		Bush	Shaft
5/8	0.85	0.188 x 0.088	0.188 x 0.107
3/4	0.83	0.188 x 0.088	0.188 x 0.107
7/8	0.80	0.250 x 0.115	0.250 x 0.142
15/16	0.79	0.250 x 0.115	0.250 x 0.142
1	0.77	0.250 x 0.115	0.250 x 0.142
1.1/8	0.74	0.312 x 0.112	0.312 x 0.177
1.3/16	0.72	0.312 x 0.112	0.312 x 0.177
1.1/4	0.70	0.312 x 0.112	0.312 x 0.177
1.5/16	0.68	0.375 x 0.11	0.375 x 0.213
1.3/8	0.66	0.375 x 0.11	0.375 x 0.213
1.7/16	0.64	0.375 x 0.11	0.375 x 0.213
1.1/2	0.61	0.375 x 0.11	0.375 x 0.213
1.5/8	0.56	0.438 x 0.134	0.438 x 0.248
1.3/4	0.51	0.438 x 0.134	0.438 x 0.248
1.7/8	0.45	0.500 x 0.131	0.500 x 0.283
1.15/16	0.42	0.500 x 0.131	0.500 x 0.283
2	0.39	0.500 x 0.131	0.500 x 0.283

2517

Bore	Mass kg	Keyseat	
		Bush	Shaft
3/4	1.77	0.188 x 0.088	0.188 x 0.107
7/8	1.74	0.250 x 0.115	0.250 x 0.142
15/16	1.72	0.250 x 0.115	0.250 x 0.142
1	1.70	0.250 x 0.115	0.250 x 0.142
1.1/8	1.65	0.312 x 0.112	0.312 x 0.177
1.1/4	1.60	0.312 x 0.112	0.312 x 0.177
1.3/8	1.54	0.375 x 0.110	0.375 x 0.213
1.7/16	1.51	0.375 x 0.110	0.375 x 0.213
1.1/2	1.48	0.375 x 0.110	0.375 x 0.213
1.5/8	1.41	0.438 x 0.134	0.438 x 0.248
1.11/16	1.38	0.438 x 0.134	0.438 x 0.248
1.3/4	1.33	0.438 x 0.134	0.438 x 0.248
1.7/8	1.25	0.500 x 0.131	0.500 x 0.263
1.15/16	1.21	0.500 x 0.131	0.500 x 0.263
2	1.17	0.500 x 0.131	0.500 x 0.283
2.1/8	1.07	0.625 x 0.185	0.625 x 0.354
2.3/16	1.03	0.625 x 0.185	0.625 x 0.354
2.1/4	0.98	0.625 x 0.185	0.625 x 0.354
2.3/8	0.88	0.625 x 0.185	0.625 x 0.354
2.1/2	0.77	0.625 x 0.185	0.625 x 0.354

2525

Bore	Mass kg	Keyseat	
		Bush	Shaft
7/8	2.38	0.250 x 0.115	0.250 x 0.142
1	2.31	0.250 x 0.115	0.250 x 0.142
1.1/8	2.24	0.312 x 0.112	0.312 x 0.177
1.1/4	2.19	0.312 x 0.112	0.312 x 0.177
1.3/8	1.99	0.375 x 0.110	0.375 x 0.213
1.1/2	1.97	0.375 x 0.110	0.375 x 0.213
1.5/8	1.94	0.438 x 0.134	0.438 x 0.248
1.3/4	1.82	0.438 x 0.134	0.438 x 0.248
1.7/8	1.72	0.500 x 0.131	0.500 x 0.283
2	1.58	0.500 x 0.131	0.500 x 0.283
2.1/8	1.45	0.625 x 0.185	0.625 x 0.364
2.1/4	1.31	0.625 x 0.185	0.625 x 0.354
2.3/8	1.18	0.625 x 0.185	0.625 x 0.354
2.1/2	1.01	0.625 x 0.153*	0.625 x 0.354

3020

Bore	Mass kg	Keyseat	
		Bush	Shaft
1.1/4	3.07	0.312 x 0.112	0.212 x 0.177
1.3/8	3.00	0.375 x 0.110	0.375 x 0.213
1.1/2	2.93	0.375 x 0.110	0.375 x 0.213
1.5/8	2.85	0.438 x 0.134	0.438 x 0.248
1.11/16	2.81	0.438 x 0.134	0.438 x 0.248
1.3/4	2.76	0.438 x 0.134	0.438 x 0.248
1.7/8	2.67	0.500 x 0.131	0.500 x 0.283
2	2.57	0.500 x 0.131	0.500 x 0.283
2.1/8	2.47	0.625 x 0.185	0.625 x 0.354
2.3/16	2.42	0.625 x 0.185	0.625 x 0.354
2.1/4	2.36	0.625 x 0.185	0.625 x 0.354
2.3/8	2.24	0.625 x 0.185	0.625 x 0.354
2.7/16	2.18	0.625 x 0.185	0.625 x 0.354
2.1/2	2.12	0.625 x 0.185	0.625 x 0.354
2.5/8	1.99	0.750 x 0.209	0.750 x 0.424
2.11/16	1.92	0.750 x 0.209	0.750 x 0.424
2.3/4	1.85	0.750 x 0.209	0.750 x 0.424
2.7/8	1.78	0.750 x 0.209	0.750 x 0.424
2.15/16	1.67	0.750 x 0.209	0.750 x 0.424
3	1.56	0.750 x 0.209	0.750 x 0.424

3030

Bore	Mass kg	Keyseat	
		Bush	Shaft
1.1/4	4.44	0.312 x 0.112	0.312 x 0.177
1.3/8	4.34	0.375 x 0.110	0.375 x 0.213
1.1/2	4.23	0.375 x 0.110	0.375 x 0.213
1.5/8	4.12	0.438 x 0.134	0.438 x 0.248
1.3/4	3.99	0.438 x 0.134	0.438 x 0.248
1.7/8	3.85	0.500 x 0.131	0.500 x 0.283
2	3.70	0.500 x 0.131	0.500 x 0.283
2.1/8	3.55	0.625 x 0.185	0.625 x 0.354
2.1/4	3.38	0.625 x 0.185	0.625 x 0.354
2.3/8	3.21	0.625 x 0.185	0.625 x 0.354
2.1/2	3.02	0.625 x 0.185	0.625 x 0.354
2.5/8	2.83	0.750 x 0.209	0.750 x 0.424
2.11/16	2.73	0.750 x 0.209	0.750 x 0.424
2.3/4	2.62	0.750 x 0.209	0.750 x 0.424
2.7/8	2.41	0.750 x 0.209	0.750 x 0.424
3	2.19	0.750 x 0.209	0.750 x 0.424

Bold italic type indicates bushes made of steel.

Keyways are parallel and in accordance with BS46:Part 1:1958, with the exception of those marked* which are shallower.

Depth of key measured at centre.

All dimensions are in inches

Taper Bushes - Imperial

3525

Bore	Mass kg	Keyseat	
		Bush	Shaft
1.1/2	5.28	0.375 x 0.110	0.375 x 0.213
1.5/8	5.18	0.438 x 0.134	0.438 x 0.248
1.3/4	5.08	0.438 x 0.134	0.438 x 0.248
1.7/8	4.96	0.500 x 0.131	0.500 x 0.283
2	4.84	0.500 x 0.131	0.500 x 0.283
2.1/8	4.71	0.625 x 0.185	0.625 x 0.354
2.1/4	4.57	0.625 x 0.185	0.625 x 0.354
2.3/8	4.42	0.625 x 0.185	0.625 x 0.354
2.1/2	4.27	0.625 x 0.185	0.625 x 0.354
2.5/8	4.11	0.750 x 0.209	0.750 x 0.424
2.3/4	3.94	0.750 x 0.209	0.750 x 0.424
2.7/8	3.76	0.750 x 0.209	0.750 x 0.424
3	3.58	0.750 x 0.209	0.750 x 0.424
3.1/8	3.38	0.875 x 0.264	0.875 x 0.495
3.1/4	3.18	0.875 x 0.264	0.875 x 0.495
3.3/8	2.07	0.875 x 0.264	0.875 x 0.495
3.1/2	2.80	0.875 x 0.264	0.875 x 0.495
3.3/4*	2.50	0.000 x 0.245*	1.000 x 0.566
4*	2.20	0.000 x 0.155*	1.000 x 0.566

3535

Bore	Mass kg	Keyseat	
		Bush	Shaft
1.1/2	7.16	0.375 x 0.110	0.375 x 0.213
1.5/8	7.02	0.438 x 0.134	0.438 x 0.248
1.3/4	6.88	0.438 x 0.134	0.438 x 0.248
1.7/8	6.73	0.500 x 0.131	0.500 x 0.283
2	6.55	0.500 x 0.131	0.500 x 0.283
2.1/8	6.36	0.625 x 0.185	0.625 x 0.354
2.1/4	6.16	0.625 x 0.185	0.625 x 0.354
2.3/8	5.96	0.625 x 0.185	0.625 x 0.354
2.1/2	5.75	0.625 x 0.185	0.625 x 0.354
2.5/8	5.51	0.750 x 0.209	0.750 x 0.424
2.3/4	5.28	0.750 x 0.209	0.750 x 0.424
2.7/8	5.02	0.750 x 0.209	0.750 x 0.424
3	4.77	0.750 x 0.209	0.750 x 0.424
3.1/8	4.50	0.875 x 0.264	0.875 x 0.495
3.1/4	4.21	0.875 x 0.264	0.875 x 0.495
3.3/8	3.92	0.875 x 0.264	0.875 x 0.495
3.1/2	3.62	0.875 x 0.264	0.875 x 0.495

4030

Bore	Mass kg	Keyseat	
		Bush	Shaft
1.3/4	8.33	0.438 x 0.134	0.438 x 0.248
1.7/8	8.19	0.500 x 0.131	0.500 x 0.283
2	8.04	0.500 x 0.131	0.500 x 0.283
2.1/8	7.88	0.625 x 0.185	0.625 x 0.354
2.1/4	7.71	0.625 x 0.185	0.625 x 0.354
2.3/8	7.54	0.625 x 0.185	0.625 x 0.354
2.1/2	7.36	0.625 x 0.185	0.625 x 0.354
2.5/8	7.16	0.750 x 0.209	0.750 x 0.424
2.3/4	6.96	0.750 x 0.209	0.750 x 0.424
2.7/8	6.75	0.750 x 0.209	0.750 x 0.424
3	6.53	0.750 x 0.209	0.750 x 0.424
3.1/8	6.28	0.875 x 0.264	0.875 x 0.495
3.1/4	6.05	0.875 x 0.264	0.875 x 0.495
3.3/8	5.80	0.875 x 0.264	0.875 x 0.495
3.1/2	5.54	0.875 x 0.264	0.875 x 0.495
3.3/4	4.98	1.000 x 0.318	1.000 x 0.566
4	4.40	1.000 x 0.318	1.000 x 0.566
4.1/4	4.00	1.250 x 0.366	1.250 x 0.707
4.1/2*	3.70	1.250 x 0.255*	1.250 x 0.707

4040

Bore	Mass kg	Keyseat	
		Bush	Shaft
1.3/4	10.92	0.438 x 0.134	0.438 x 0.248
1.7/8	10.61	0.500 x 0.131	0.500 x 0.283
2	10.42	0.500 x 0.131	0.500 x 0.283
2.1/8	10.21	0.625 x 0.185	0.625 x 0.354
2.1/4	9.99	0.625 x 0.185	0.625 x 0.354
2.3/8	9.71	0.625 x 0.185	0.625 x 0.354
2.1/2	9.51	0.625 x 0.185	0.625 x 0.354
2.5/8	9.15	0.750 x 0.209	0.750 x 0.424
2.3/4	8.97	0.750 x 0.209	0.750 x 0.424
2.7/8	8.09	0.750 x 0.209	0.750 x 0.424
3	8.40	0.750 x 0.209	0.750 x 0.424
3.1/8	8.09	0.875 x 0.264	0.875 x 0.495
3.1/4	7.76	0.875 x 0.264	0.875 x 0.495
3.3/8	7.43	0.875 x 0.264	0.875 x 0.495
3.1/2	7.08	0.875 x 0.264	0.875 x 0.495
3.3/4	6.35	1.000 x 0.318	1.000 x 0.566
3.15/16	5.96	1.000 x 0.318	1.000 x 0.566
4	5.56	1.000 x 0.318	1.000 x 0.566

Bold italic type indicates bushes made of GGG Cast Iron.

Keyways are parallel and in accordance with BS46:Part 1:1958, with the exception of those marked* which are shallower.

Depth of key measured at centre.

All dimensions are in inches

Taper Bushes - Imperial

4535

Bore	Mass kg	Keyseat	
		Bush	Shaft
2.1/4	10.38	0.625 x 0.185	0.625 x 0.354
2.3/8	10.19	0.625 x 0.185	0.625 x 0.354
2.1/2	9.99	0.625 x 0.185	0.625 x 0.354
2.5/8	9.76	0.750 x 0.209	0.750 x 0.424
2.3/4	9.53	0.750 x 0.209	0.750 x 0.424
2.7/8	9.28	0.750 x 0.209	0.750 x 0.424
3	9.02	0.750 x 0.209	0.750 x 0.424
3.1/8	8.75	0.875 x 0.264	0.875 x 0.495
3.1/4	8.46	0.875 x 0.264	0.875 x 0.495
3.3/8	8.17	0.875 x 0.264	0.875 x 0.495
3.1/2	7.87	0.875 x 0.264	0.875 x 0.495
3.3/4	7.22	1.000 x 0.318	1.000 x 0.566
4	6.54	1.000 x 0.318	1.000 x 0.566
4.1/4	5.81	1.250 x 0.366	1.250 x 0.707
4.1/2	5.03	1.250 x 0.366	1.250 x 0.707
4.3/4	4.90	1.250 x 0.366	1.250 x 0.707
5	4.80	1.250 x 0.358	1.250 x 0.707

4545

Bore	Mass kg	Keyseat	
		Bush	Shaft
2.1/4	14.30	0.625 x 0.185	0.625 x 0.354
2.3/8	14.06	0.625 x 0.185	0.625 x 0.354
2.1/2	13.80	0.625 x 0.185	0.625 x 0.354
2.5/8	13.50	0.750 x 0.209	0.750 x 0.424
2.3/4	13.20	0.750 x 0.209	0.750 x 0.424
2.7/8	12.87	0.750 x 0.209	0.750 x 0.424
3	12.54	0.750 x 0.209	0.750 x 0.424
3.1/8	12.19	0.875 x 0.264	0.875 x 0.495
3.1/4	11.83	0.875 x 0.264	0.875 x 0.495
3.3/8	11.46	0.875 x 0.264	0.875 x 0.495
3.1/2	11.07	0.875 x 0.264	0.875 x 0.495
3.3/4	10.25	1.000 x 0.318	1.000 x 0.566
4	9.37	1.000 x 0.318	1.000 x 0.566
4.1/4	8.43	1.250 x 0.366	1.250 x 0.707
4.1/2	7.43	1.250 x 0.366	1.250 x 0.707

5040

Bore	Mass kg	Keyseat	
		Bush	Shaft
3	14.54	0.750 x 0.209	0.750 x 0.424
3.1/8	14.10	0.875 x 0.264	0.875 x 0.495
3.1/4	13.90	0.875 x 0.264	0.875 x 0.495
3.3/8	13.57	0.875 x 0.264	0.875 x 0.495
3.1/2	13.22	0.875 x 0.264	0.875 x 0.495
3.3/4	12.49	1.000 x 0.318	1.000 x 0.566
4	11.70	1.000 x 0.318	1.000 x 0.566
4.1/4	10.87	1.250 x 0.366	1.250 x 0.707
4.1/2	10.40	1.250 x 0.366	1.250 x 0.707
4.3/4	10.00	1.250 x 0.366	1.250 x 0.707
5	9.90	1.250 x 0.366	1.250 x 0.707

5050

Bore	Mass kg	Keyseat	
		Bush	Shaft
3	17.80	0.750 x 0.209	0.750 x 0.424
3.1/8	17.37	0.875 x 0.264	0.875 x 0.495
3.1/4	16.93	0.875 x 0.264	0.875 x 0.495
3.3/8	15.99	0.875 x 0.264	0.875 x 0.495
3.1/2	15.16	1.000 x 0.318	1.000 x 0.566
4	14.18	1.000 x 0.318	1.000 x 0.566
4.1/4	13.13	1.250 x 0.366	1.250 x 0.707
4.1/2	12.03	1.250 x 0.366	1.250 x 0.707
4.3/4	10.86	1.250 x 0.366	1.250 x 0.707
5	9.03	1.250 x 0.366	1.250 x 0.707

Bold italic type indicates bushes made of GGG Cast Iron.

Keyways are parallel and in accordance with BS46:Part 1:1958, with the exception of those marked* which are shallower.

Depth of key measured at centre.

All dimensions are in inches

NOTE

Challenge can manufacture larger taper bush sizes including 6050, 7060 and 8065 available to order with the following maximum bores:

6050 150 mm or 6"

7060 175 mm or 7"

8065 200 mm or 8"

Pilot bore taper bushes in these sizes are also available.