

Bolt-on-Hubs

Taper Bore Bolt-on-Hubs are designed for use with the universally accepted Taper Bush. They provide a convenient means of securing fan rotors, impellers, agitators and other devices which must be fastened firmly to shafts.

Challenge Bolt-on-Hubs, type BF and SM, complete the range. They are manufactured from GG22 cast iron and are phosphated for extra rust protection.

SM Bolt-on-Hubs

Hub Reference	Bush Number	A	B	C	D	E	F/G	H	J (No. x Diam)
SM 12	1210	180	90	135	26	6.5	80	9.75	6 x 7.5
SM 16-1	1610	200	110	150	26	7.5	90	9.25	6 x 7.5
SM 16-2	1615	200	110	150	38	7.5	90	15.25	6 x 7.5
SM 20	2012	270	140	190	32	8.5	100	11.75	6 x 9.5
SM 25	2517	340	170	240	45	9.5	119	17.75	8 x 11.5
SM 30-1	3020	430	220	300	51	13.5	147	18.75	8 x 13.5
SM 30-2	3020	485	250	340	51	13.5	147	18.75	8 x 13.5

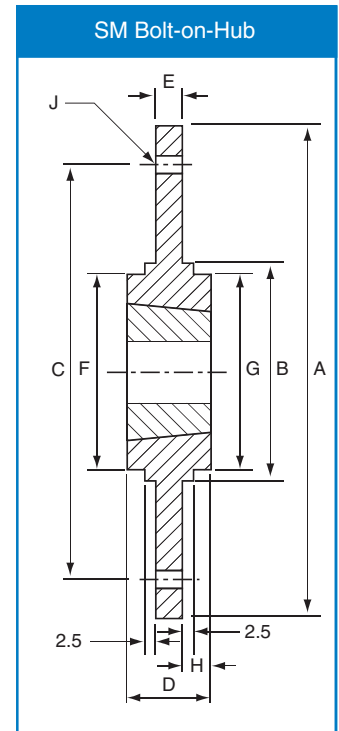

BF Bolt-on-Hubs

Hub Reference	Bush Number	A	B	C	D	E	F	G	H	J (No. x Diam)
BF12	1210	120	80	100	25	5.5	74	80	10	6 x 6.6
BF16	1610	130	90	110	25	6.5	84	90	10	6 x 6.6
BF20	2012	145	100	125	32	8.5	99	100	13	6 x 8.5
BF25	2517	185	130	155	44	11.5	120	119	20	6 x 10.5
BF30	3020	220	165	190	50	11.5	146	147	20	6 x 13.0

